



# The GoBiGas Project - Efficient transfer of biomass to biofuels



*SGC International Seminar on Gasification  
Göteborg 28-29 October 2010  
Ingemar Gunnarsson Göteborg Energi AB*

# Our vision....

---

***Göteborg Energi shall actively contribute to the development of a sustainable society in Göteborg***



# Our vision: Only renewable gas in the future

Short term target 2020 for Gothenburg > 1 TWh of biomethane

Short term target 2020 for Sweden > 15 TWh of biomethane

Long term target – only renewable energy sources

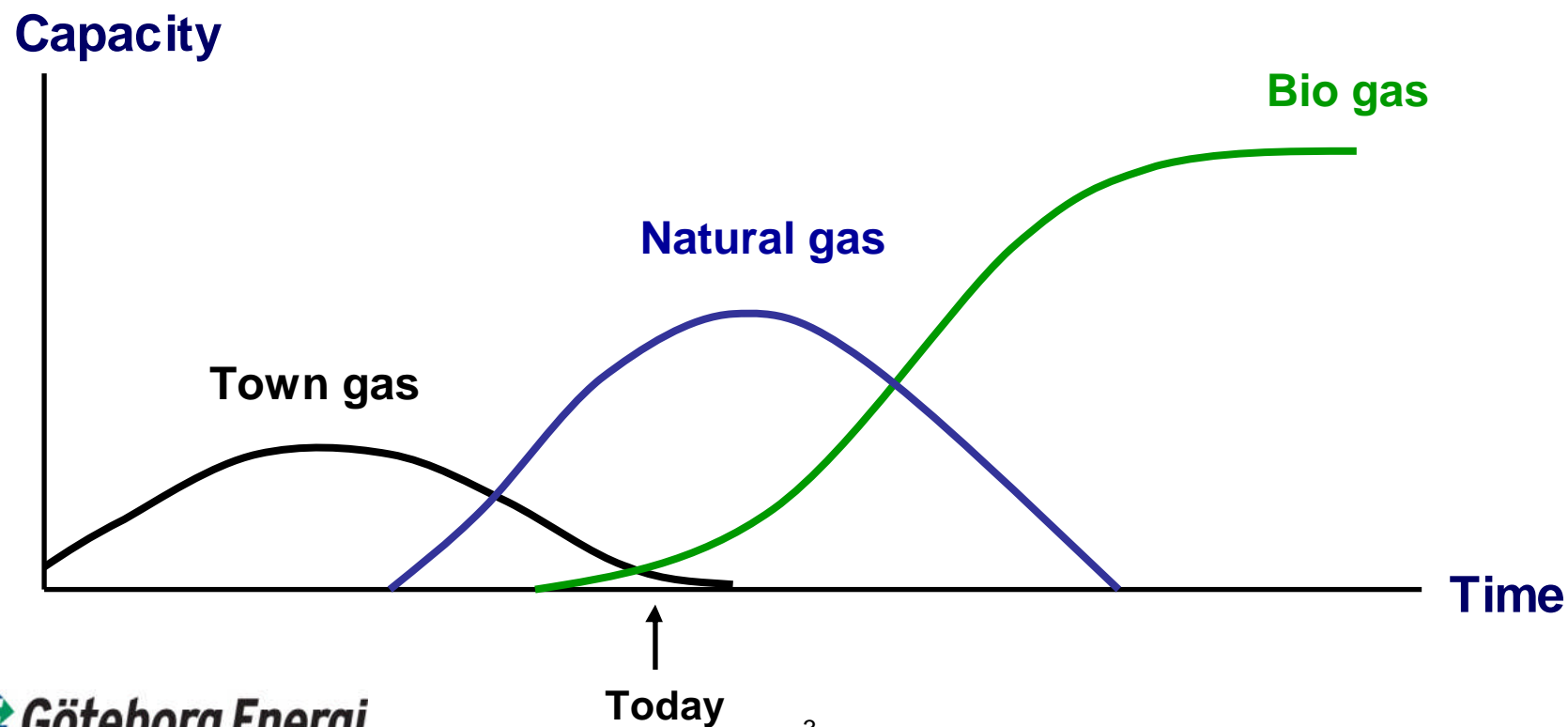

# “Green gas concept”

- A huge market potential is opened for biogas
- The reliability of the biogas supply improves

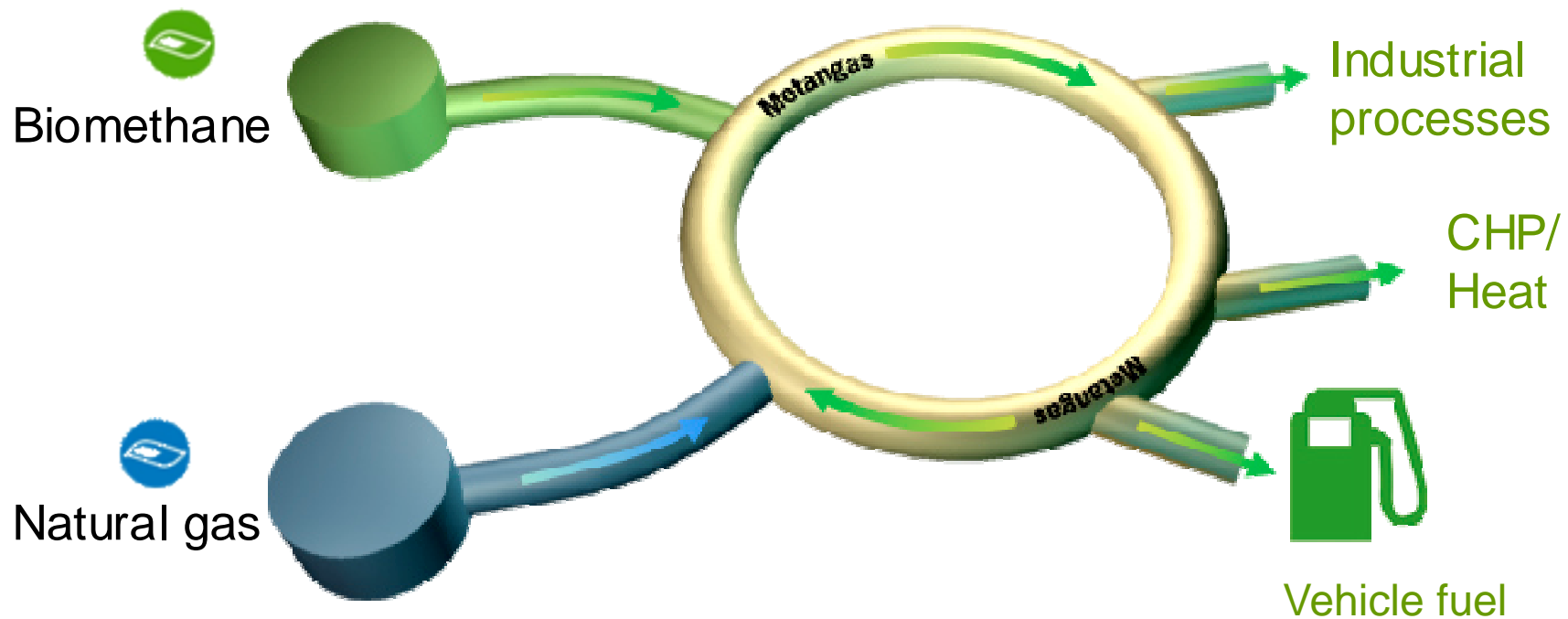

# GoBiGas – Gothenburg Biomass Gasification Project

- **Commercial scale**
  - 100 MW biomethane (biomethane)
  - Operating period 8000 hr/yr
  - ⇔ 80 MNm<sup>3</sup>/yr or 800 GWh/yr
- **Gasification** of forest residues
- Production of **biomethane for** distribution in the existing gas grid.
- Plant situated **in the harbor of Gothenburg**, fuel transport by ship or by train
- **Joint project** Göteborg Energi and E.ON



# GoBiGas – step by step

- **Performance goals:**
  - Biomass to biomethane 65 - 70%
  - Energy efficiency > 90%
- **Phase 1:**
  - Demonstration plant
  - Evaluation, R&D programme
  - 20 MW generating 160 GWh/year
  - In operation late 2012/ early 2013
  - Allothermal (in-direct) gasification
- **Phase 2:**
  - 80 MW generating 640 GWh/year
  - In operation after evaluation of Phase 1
  - Technology not yet chosen

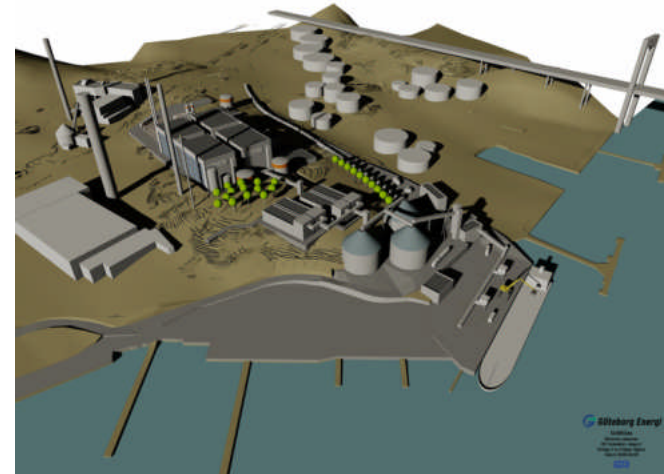

# Commercial development of gasification technology in Sweden

GoBiGas Phase 1: Large scale demonstration plant

GoBiGas Phase 2: 1/2 of specific cost compared to Phase 1?

2020: 1/3 of specific cost compared to Phase 1?

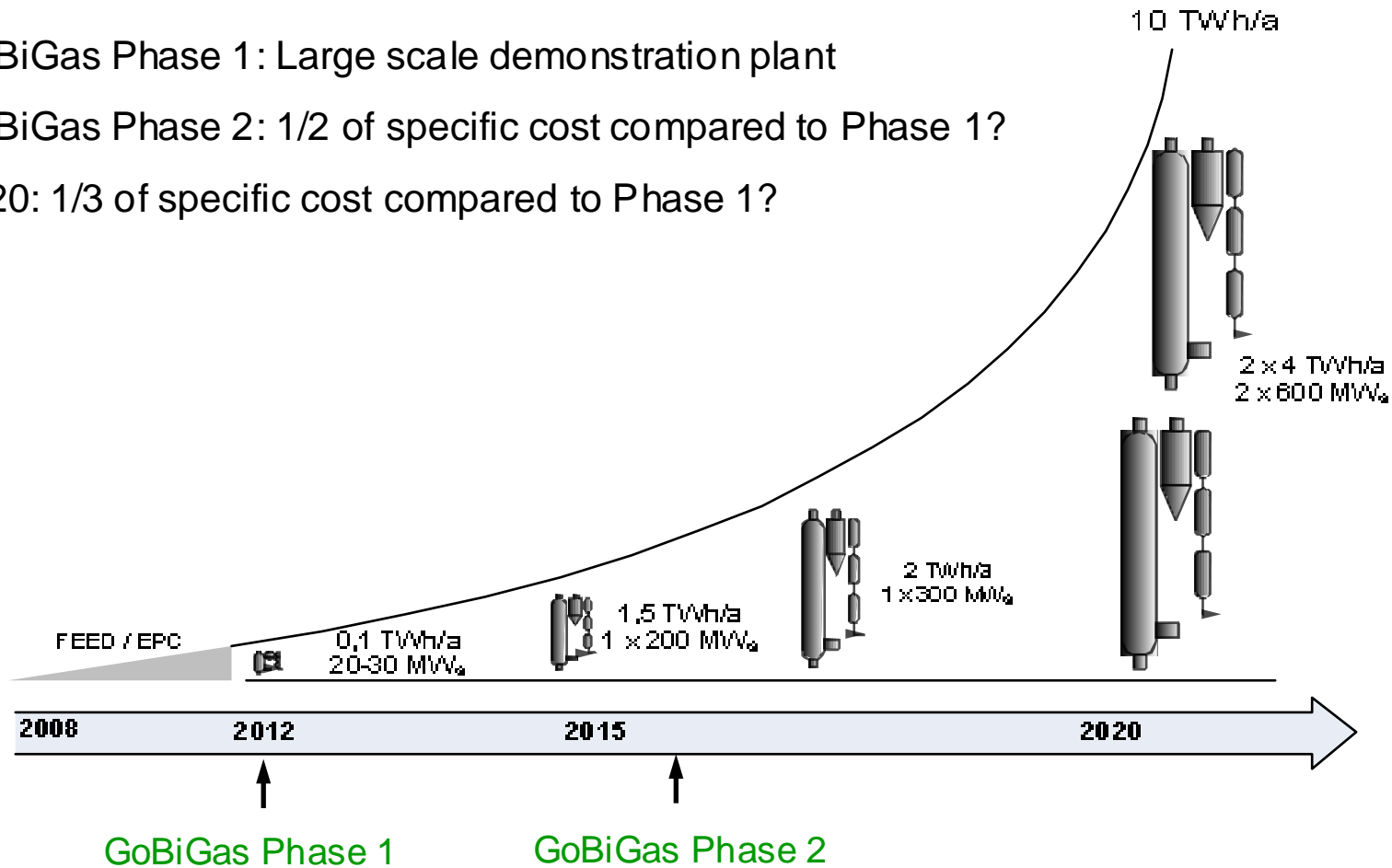

# GoBiGas – Phase 1

## Consumption:

Fuel (wood pellets) 32 MW

Electricity 3 MW

RME (bio-oil) 0,5 MW

## Production:

Biomethane 20 MW

District heating 5 MW

Heat to heat pumps 6 MW

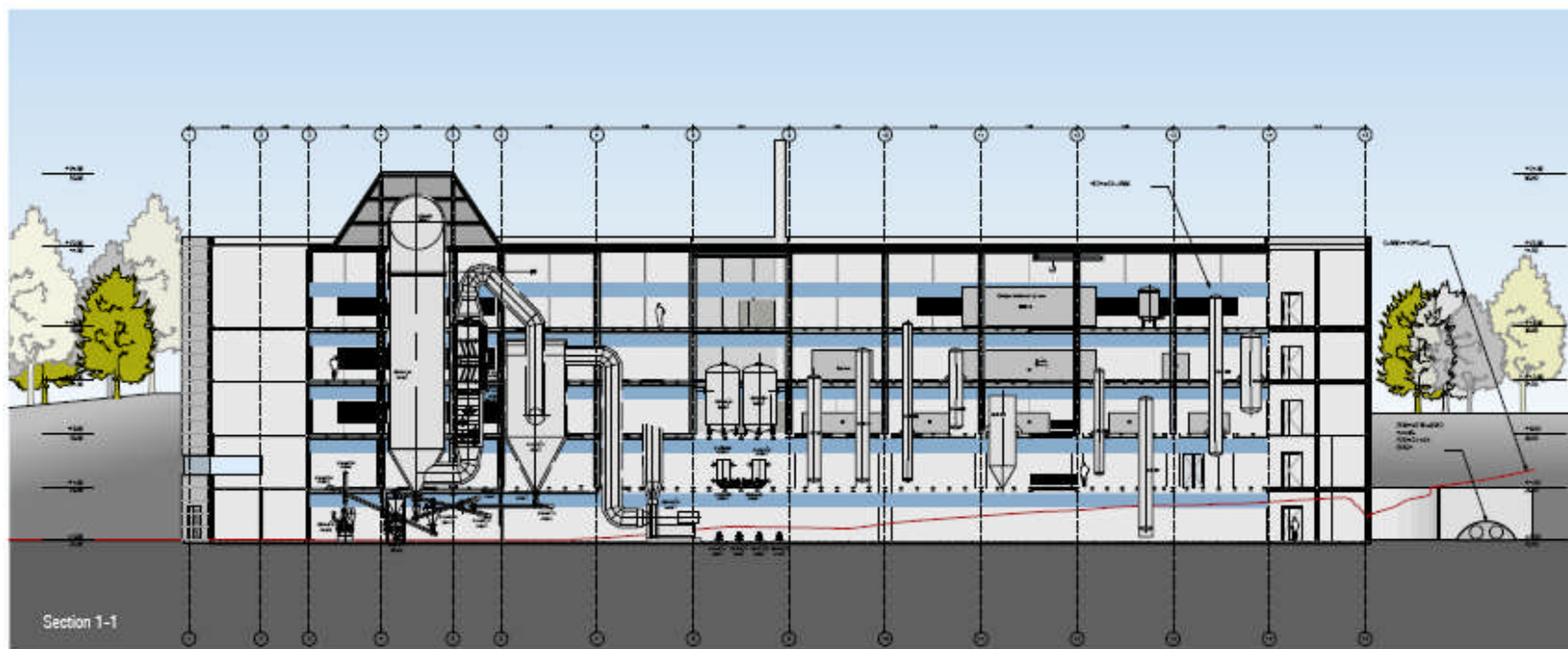

# Technical principles

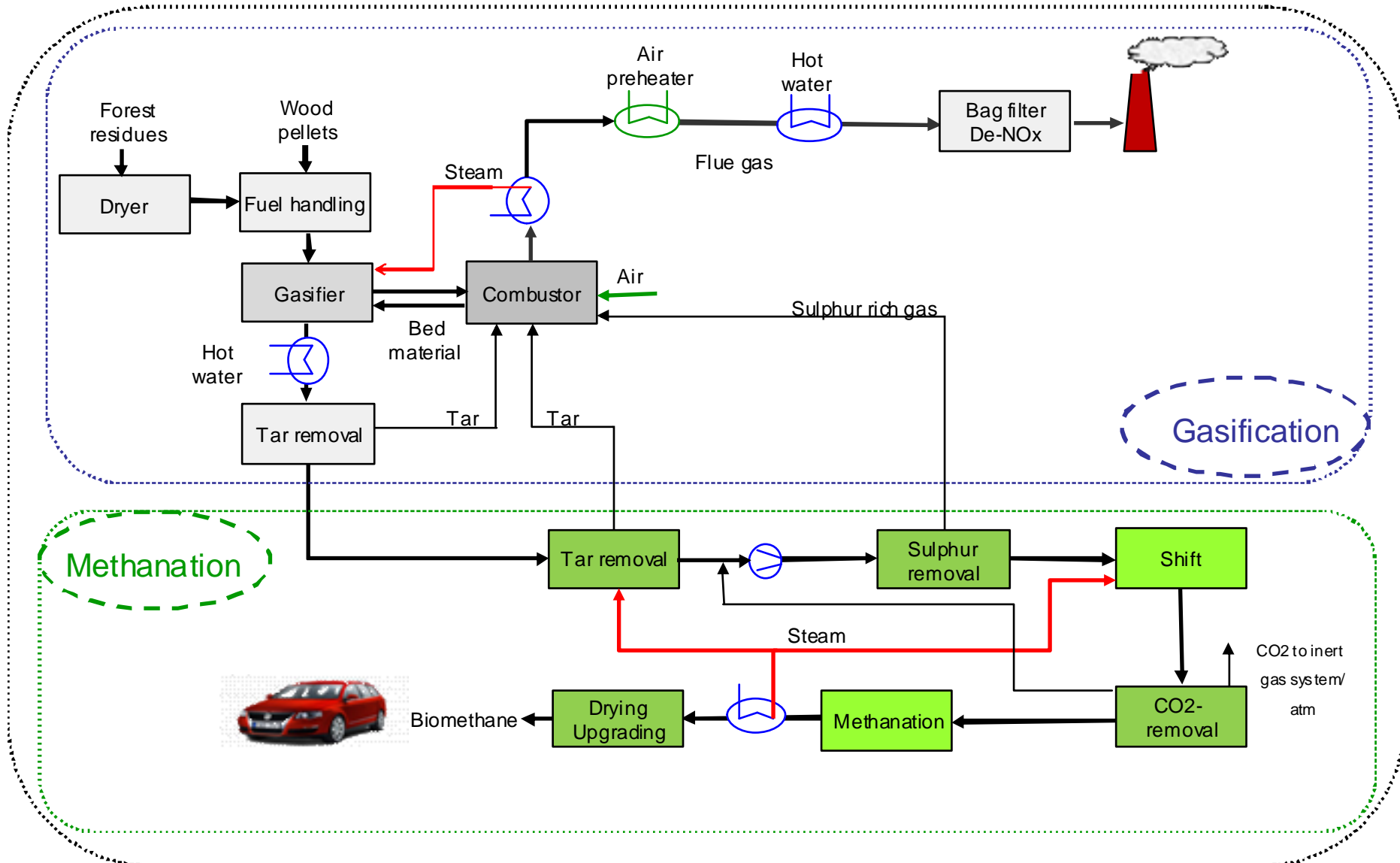

# Reference plant: Gasification in Güssing, Austria

---

- Gasification in fluidized bed with separate combustion zone (in-direct, allothermal gasification)
  - 8 MW biofuel
  - Gas engine 2 MWe and 4,5 MWth to local district heating system
  - Operating time incl. 2010 nearly 50 000 hours



# Biomass-CHP-Plant-Güssing

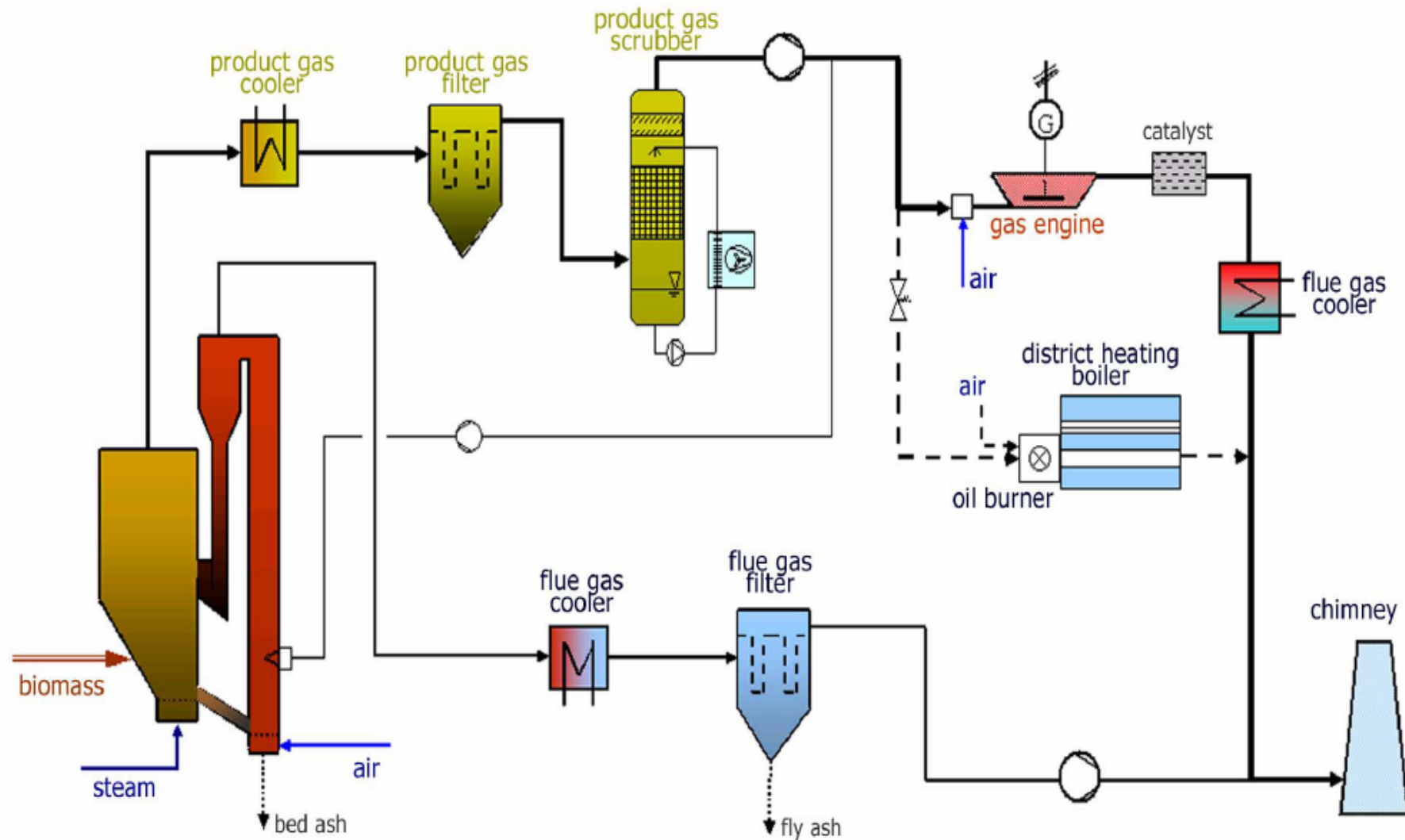



# GoBiGas – phase 1

Existing hot water boilers, fired with wood pellets

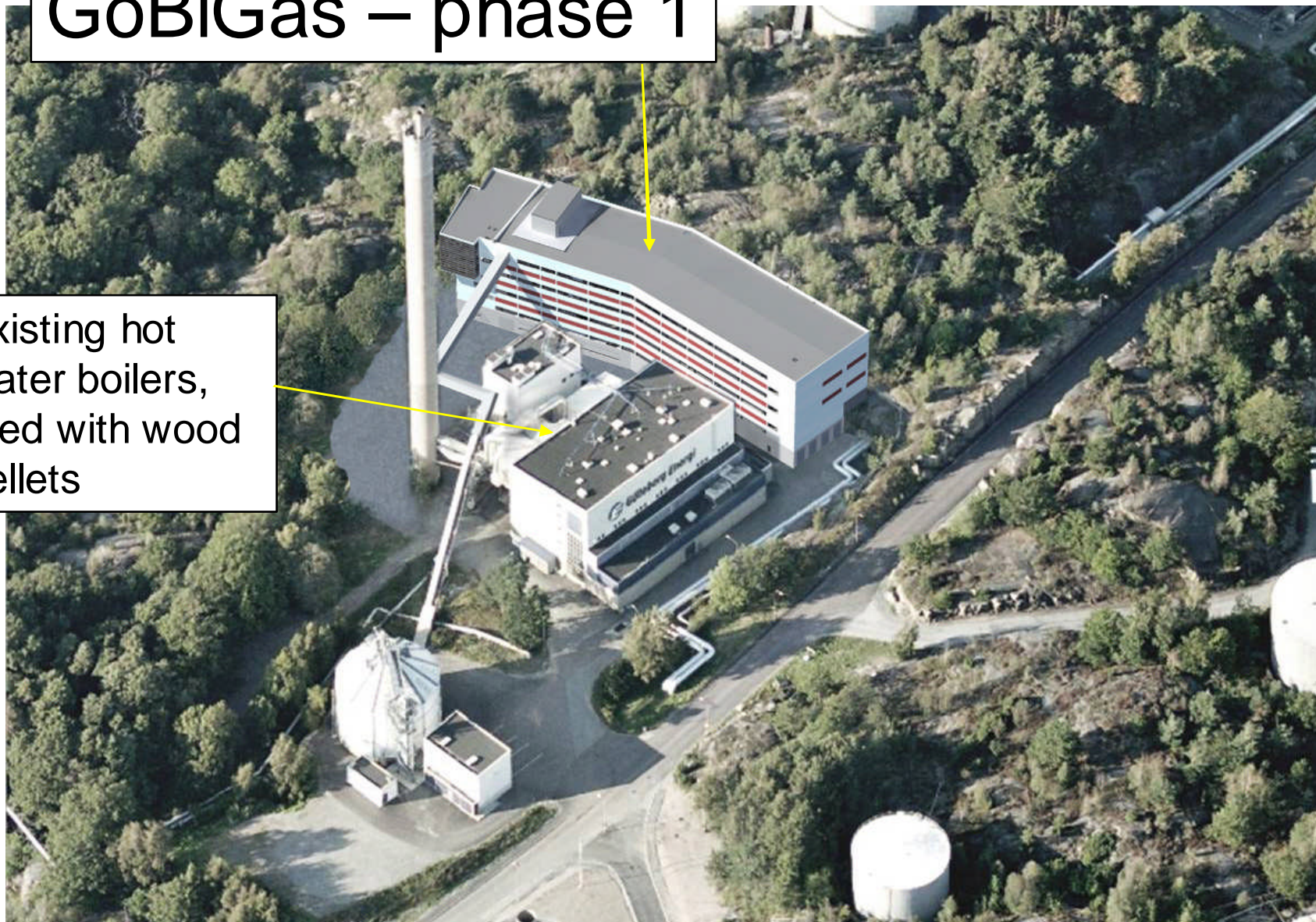

# Pilot: Gasification of biomass at Chalmers University of Technology

- Built to further develop indirect gasification and grow local expertise for future projects
- Large potential for commercialization, can be added onto any Circulating Fluidized Bed (CFB) furnace
- Currently producing 2 MW of "green gas" now being utilized in existing boiler
- Development of methanation technology would allow for local production of biomethane for e.g. vehicle fuel

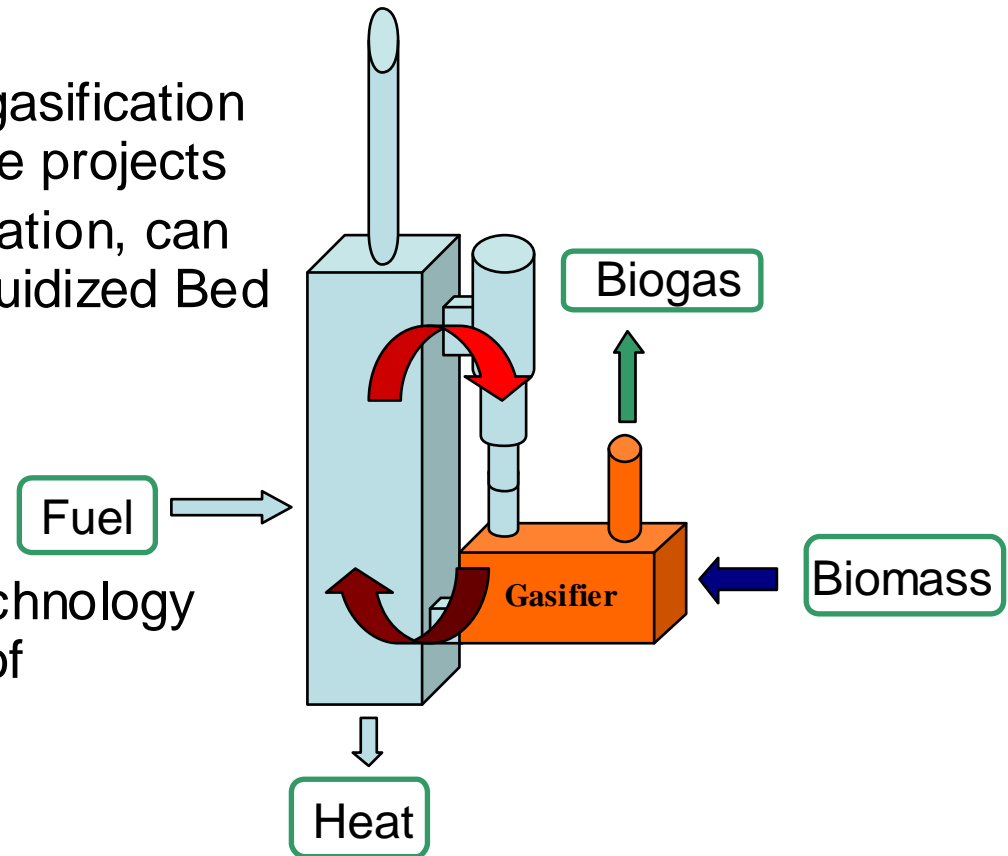

# Chalmers pilot gasifier in connection with existing boiler

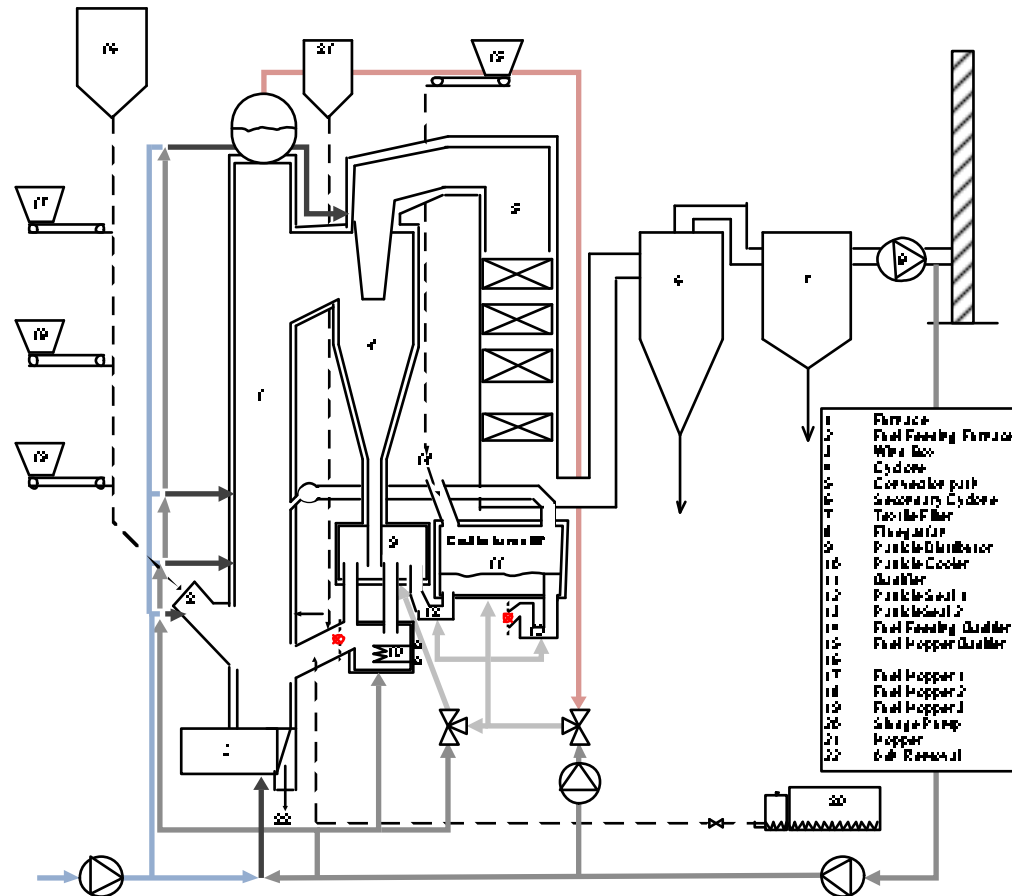

# Project status – October 2010

---

- **State funding**
    - **222 MSEK** granted from the Swedish Energy Agency under provision of approval by the EC, discussion undergoing.
  - **Gasification**
    - Cooperation between Metso Power and Repotec
  - **Methanation**
    - Cooperation with Haldor Topsöe
  - **Permits**
    - Environmental permit granted for Phase 1, applications building permit for Phase 1 in process
    - Preparatory work for environmental permit and building permit for Phase 2
- ⇒ **Investment decision** late 2010
- ⇒ **Plant in operation** late 2012



Thank you for listening!

---